

The logo for BRAVI features the word "BRAVI" in a bold, sans-serif font. The letters "BR" and "I" are dark grey, while "AVI" is red. The "A" is a stylized, upward-pointing triangle. The logo is centered horizontally and positioned above the word "PLATFORMS".

**BRAVI**

The word "PLATFORMS" is written in a bold, dark grey, sans-serif font. It is preceded by a thick red horizontal bar that is slightly shorter than the word. The entire logo is centered horizontally and positioned below the word "BRAVI".

**PLATFORMS**





**Leonardo HD**  
Indoor & Outdoor



**Solo-Gyps**



**Small-E**



**LUI 460**



**Spin-Go**



**Sprint**



**Sprint TL**









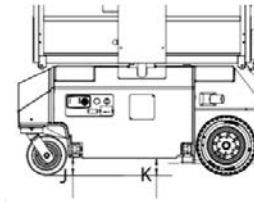
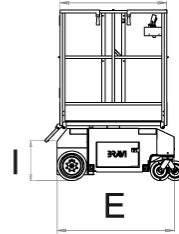
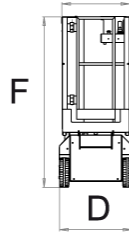
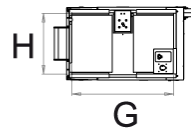
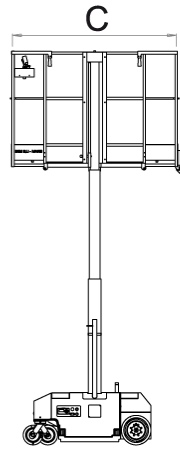
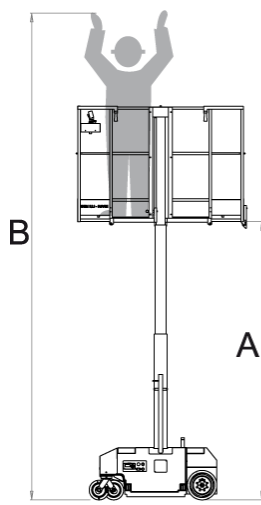



**Sprint LP**

# Leonardo HD







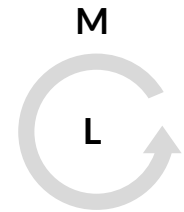

	METRIC	US (ANSI compliant)
A	2900 mm	9 ft 6 in
B	4900 mm	16 ft
C	1700 mm	67 in
D	760 mm	30 in
E	1192 mm	47 in
F	1747 mm	68.7 in
G	1036 mm	40.7 in
H	630 mm	24.8 in
I	400 mm	15.7 in
J	92 mm	3.6 in
K	87 mm	3.4 in
	180 kg	397 lbs
	530 kg	1170 lbs
	560 kg	1234 lbs
	1	1
	3 Km/h	1.9 mph
	0,6 Km/h	0.35 mph
	16 / 21 sec	16 / 21 sec
L	ZERO	ZERO
M	1200 mm	3 ft 11 in
	One hand proportional controller	One hand proportional controller
	35%	35%
	1.1 Imp. gal	1.3 U.S. gal
	110/220 V ca 24Vcc	110/220 V ca 24Vcc
	n° 2 - 12V; 85Ah@20h 105Ah@20h	n° 2 - 12V; 85Ah@20h 105Ah@20h

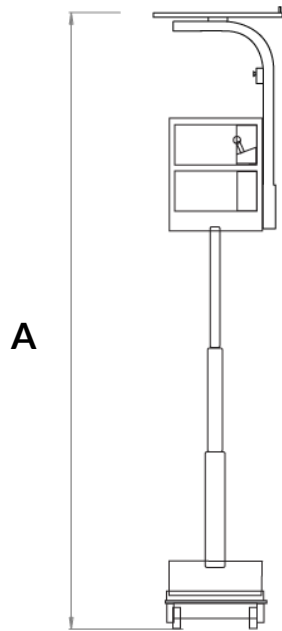

# Solo-Gyps

## Drywall lifter attachment



	METRIC	US
A	4900 mm	16 ft
	45 kg	99.3 lbs
	40 kg	88.3 lbs
	max. 3650 mm	max. 12 ft



# Small-E

## Inspection device

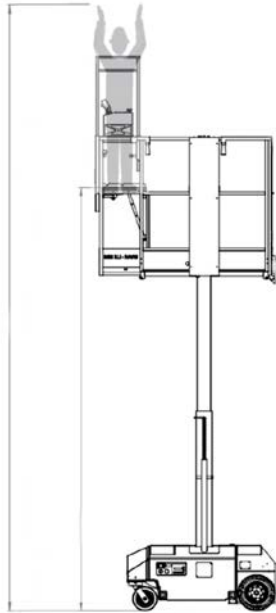

	METRIC	US
<b>A</b>	5567 mm	18.2 ft
<b>Load rating (w/ operator)</b>	113 kg	249 lbs
<b>Net weight</b>	32 kg	70 lbs
<b>Frame width</b>	350 mm	13.7 in
<b>Frame height</b>	1110 mm	43.7 in



# LUI 460





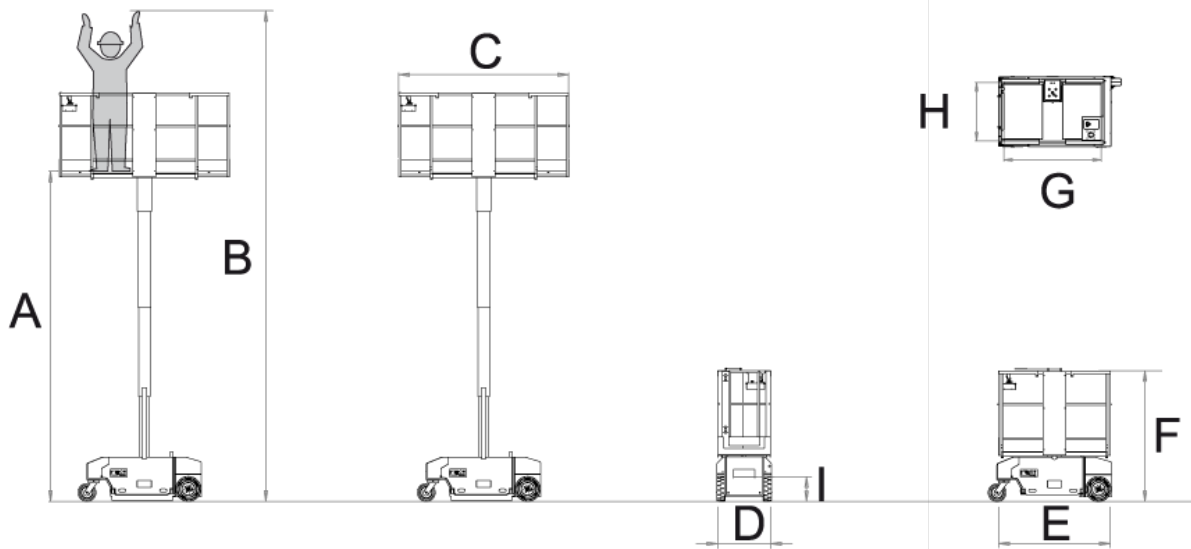

	METRIC	US
A	4620 mm	15 ft 2 in
B	6620 mm	21 ft 8 in
C	2376 mm	7 ft 9.5 in
D	760 mm	29 in
E	1659 mm	5 ft 5 in
F	1850 mm	1850 mm
G	1560 mm	5 ft
H	680 mm	27 in
I	340 mm	13.4 in
	100 mm	4 in
	280 kg	617 lbs
	1250 kg	2755 lbs
	2	2
	3 Km/h	1.9 mph
	0,6 Km/h	0.35 mph
L	ZERO	ZERO
M	1700 mm	67 in
	35%	35%
	110/220 V ca 24Vcc	110/220 V ca 24Vcc
	n° 2 - 12V; 85Ah@20h 105Ah@20h	n° 2 - 12V; 85Ah@20h 105Ah@20h

# Options and Accessories



**AGM BATTERIES**



**MAGNETIC  
STORAGE BOX**



**TOOLBOX**



**GUARD ON  
TOP CONTROL**



**TELEMATICS**



**OIL-LEAK PROTECTION**









**BIODEGRADABLE  
HYDRAULIC OIL**

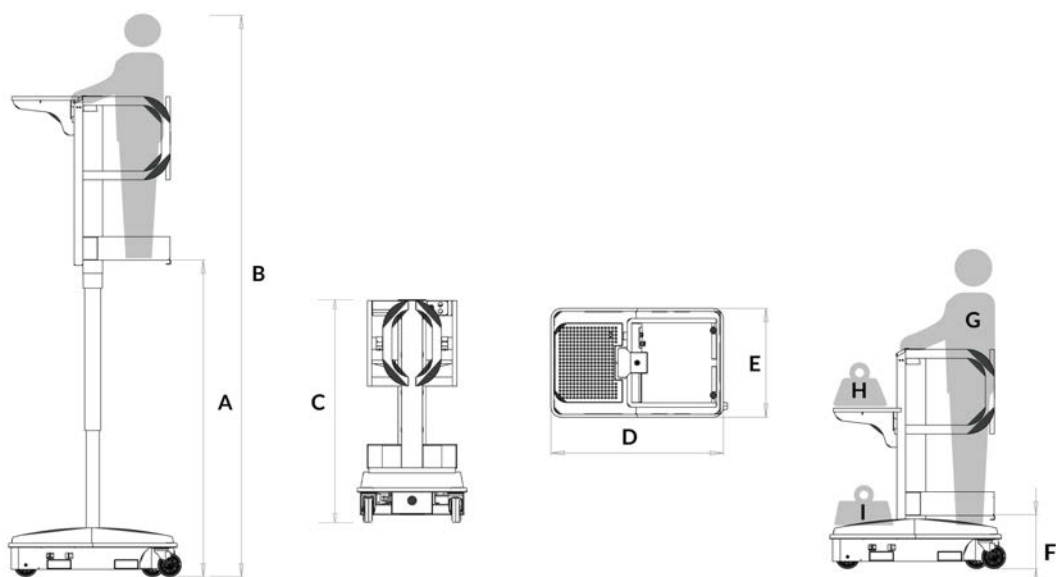

# Spin-Go





	METRIC	US (ANSI compliant)
A	2168 mm	7 ft 11 in
B	4168 mm	13 f 67 in
C	1480 mm	4 ft 8 in
D	1163 mm	3 ft 8 in
E	730 mm	28.7 in
F	367 mm	14.4 in
 G	130 kg	286.6 lbs
 H	90 kg	198.4 lbs
 I	90 kg	198.4 lbs
	280 kg	617 lbs
	1	1
	110/220 V ca 12 Vcc	
	N° 1 12V; 85Ah@20h	

# Sprint



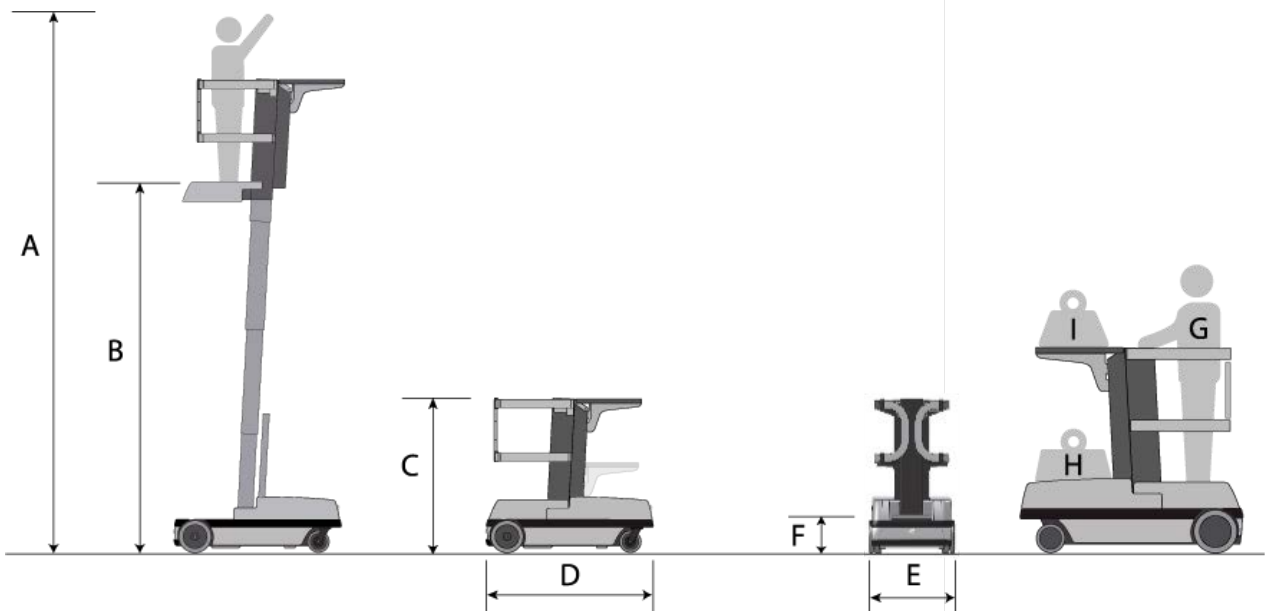

	METRIC	US (ANSI compliant)
A	5350 mm	17 ft 6 in
B	3350 mm	10 ft 11 in
C	1440 mm	4 ft 8 in
D	1500 mm	4 ft 11 in
E	808 mm	31.8 in
F	360 mm	14 in
G	130 kg	286 lbs
H	90 kg	198.4 lbs
I	113 kg	249 lbs
	690 kg	1521 lbs
	1	1
	5 Km/h	3.1 mph
	1,2 Km/h	0.74 mph
L	ZERO	ZERO
M	1600 mm	5.11 in
	2°	2°
	110/220 V ca 24Vcc	110/220 V ca 24Vcc
	n° 4 - 6V; 245Ah@20h	n° 4 - 6V; 245Ah@20h

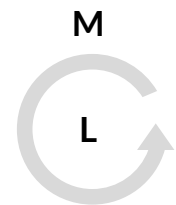







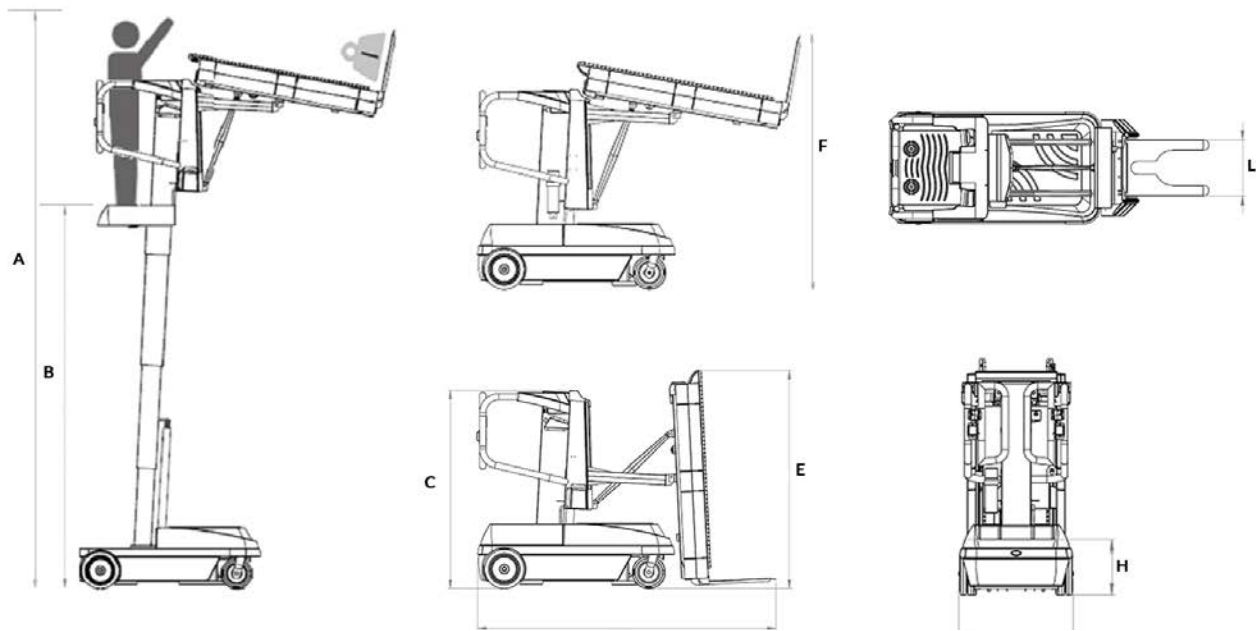

# Sprint TL







	METRICS	US (ANSI compliant)
A	5000 mm	16 ft 4 in
B	3000 mm	9 ft 10 in
C	1515 mm	4 ft 11 in
D	2275 mm	7 ft 5 in
	1778 mm	5 ft 9 in
E	1665 mm	5 ft 5 in
F	1914 mm	6 ft 3 in
G	809 mm	31 in
H	394 mm	15,5 in
I	150 kg	330 lbs
L	400 mm	15,7 in
	130 kg	286.6 lbs
	820 kg	1807 lbs
	1	1
	5 km/h	3.1 mph
	1.2 km/h	0.7 mph
	T.L. 2°	
	TLP 1,5°	
	110/220 V ca 24Vcc	
	n° 4 - 6V; 245Ah@20h	

# Sprint LP



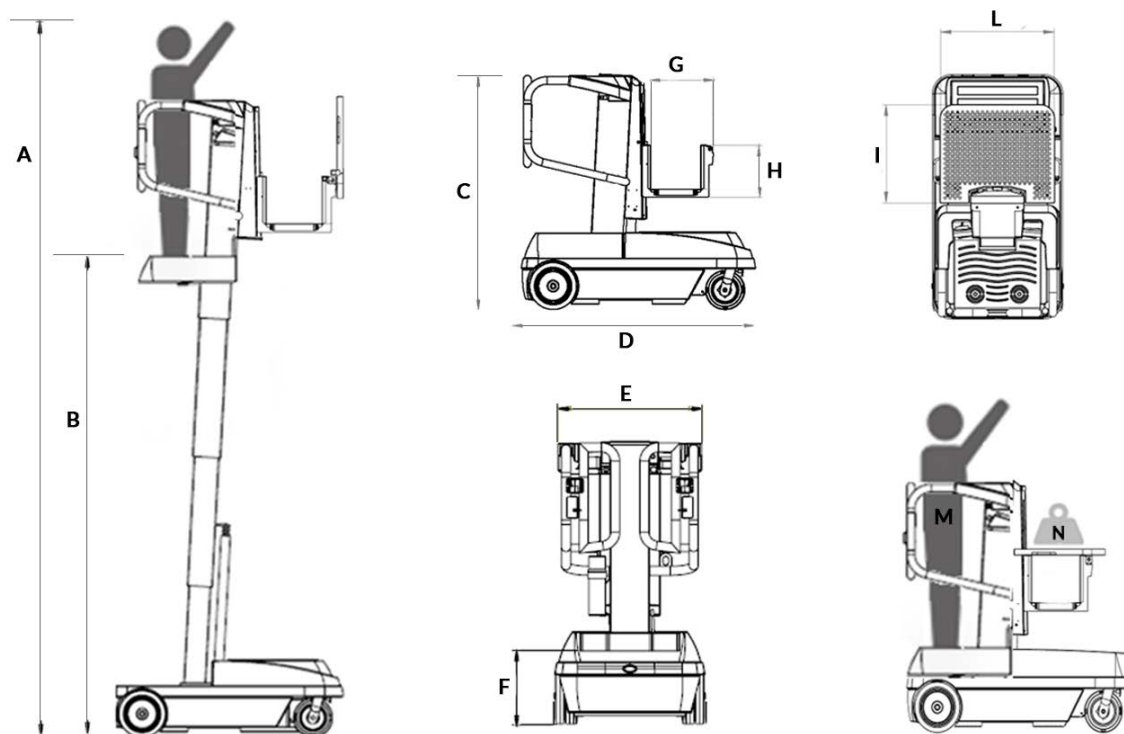

	METRIC	US (ANSI compliant)
A	5350 mm	17 ft 6 in
B	3350 mm	10 ft 11 in
C	1440 mm	4 ft 8 in
D	1500 mm	4 ft 11 in
E	776 mm	30 in
F	360 mm	14 in
G	401 mm	15 in
H	334 mm	13 in
I	600 mm	23 in
L	700 mm	27 in
M	130 kg	286 lbs
N	90 kg	198 lbs
	714 kg	1574 lbs
	1	1
	5 Km/h	3.1 mph
	1,2 Km/h	0.74 mph
	2°	2°
	110/220 V ca 24Vcc	110/220 V ca 24Vcc
	n° 4 - 6V; 245Ah@20h	n° 4 - 6V; 245Ah@20h

# Options and Accessories



**SIDE GUIDE ROLLERS**



**WHEEL-LOCK**



**COMPLETE GATE INTERLOCK**



**GATE ALARM**



**HOOK FOR TRAILER**



**TRAILER**



**IRON BUMPER KIT**

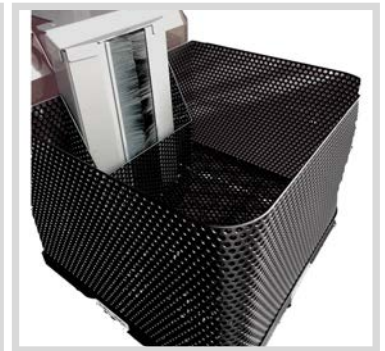

**BOX-SHAPED LOAD DECK**



**LED LIGHTS**



**BOTTLE HOLDER**



**KEYPAD**



**SCANNER HOLDER**

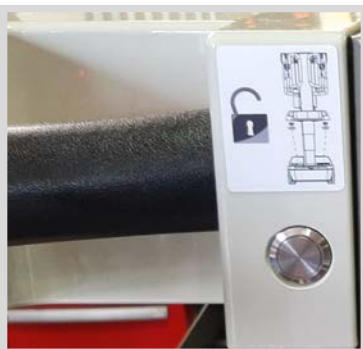

**ARMGUARD SENSOR KIT**



**CLOTHES HANGER**



**MAGNETIC STORAGE BOX**



**AGM OR LITHIUM BATTERIES**

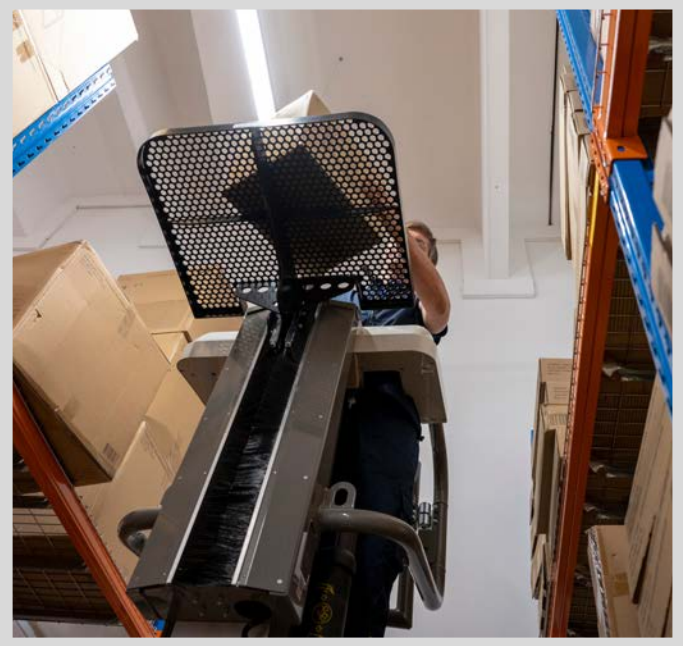



# NEED **BRAVI** SPARE PARTS?

**BRAVI** PARTS  
— PLATFORMS

[www.bravi-parts.com](http://www.bravi-parts.com)

**Sign up and place your order now!**

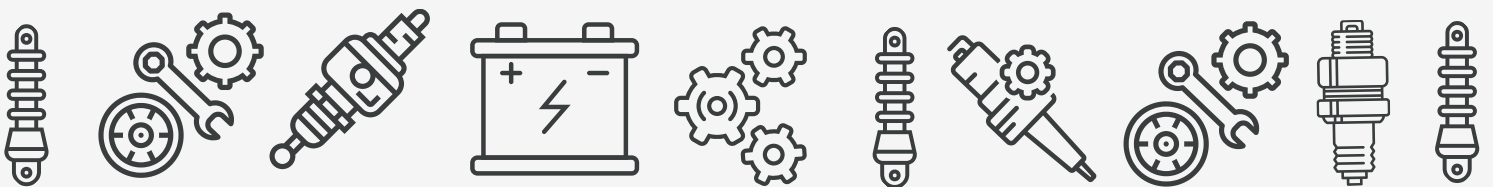

Follow us on



@braviplatforms





# **BR****AVI**

## **— PLATFORMS**

Braviisol D.M. SRL  
SS Adriatica 16 km 314.600  
60022 Castefidardo (AN) ITALY  
[www.bravi-platforms.com](http://www.bravi-platforms.com)